

SPECIFICATIONS FOR LCD MODULE

CUSTOMER	
MODEL	SCT009004-V01
CUSTOMER APPROVED	

APPROVED BY	CHECKED BY	ORGANIZED BY
	Lr.Yin	Wf.Luo



1.CONTENT 目录

1. General Spec-----	P4
2. Mechanical drawing -----	P5
3. Interface description-----	P6
4. Absolute Maximum Rating -----	P7
5. DC. Characteristics -----	P7
6. Timing characteristics -----	P8
7. Backlight characteristics-----	P11
8. Electron-Optical Characteristics -----	P11
9. Reliability -----	P14
10. Quality level-----	P15
11. Handling Precautions -----	P16
12. Precaution For Use -----	P17

2.REVISION RECORD 版本状态

Version 版本	Revision Items 修改内容	Page 页	Name 修改人	Date 发行日期
1.0	First release			2019.06.20

1.General Spec

Item	Standard values	Unit 单位
LCD type	0.96 " TFT	-
Dot arrangement	240(RGB)*198	dots
Color filter array	RGB -stripc	-
Display mode	IPS/ Transmissive / Normal Black	-
Viewing direction(Gray inversion)	Free	-
Driver IC	GC9307	V
Module size	27.40(W) X 27.00(H) X 1.46(T)	mm
Active area	24.408(H) X 20.137(V)	mm
Dot pitch	0.1017 (H) × 0.1017 (V)	mm
Interface	1 Lane 4SPI /8080 mode	-
Operating temperature	-10~60	°C
Storage temperature	-20~70	°C

2.Mechanical drawing

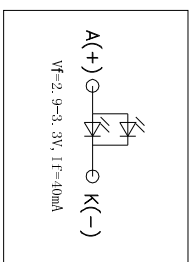
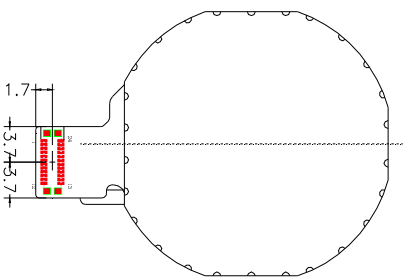
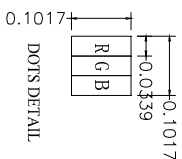
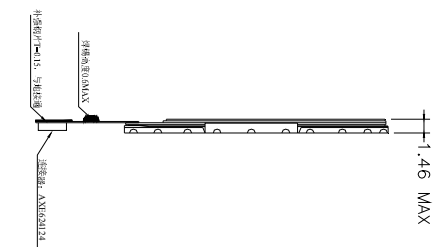
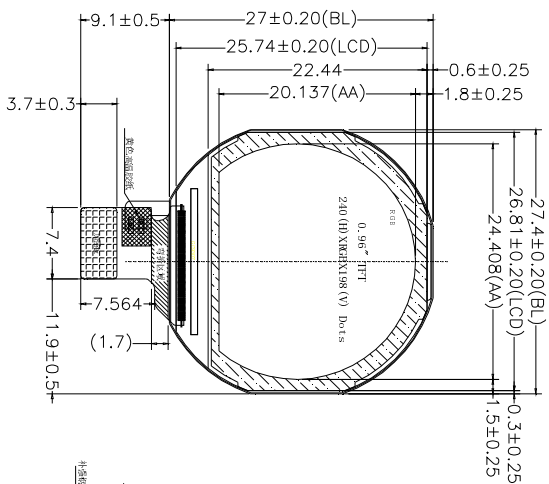

Pin Assignment	
1	VSS
2	IM1\2
3	RES
4	NC
5	CS
6	DCX/SCL
7	NC
8	VDDIO
9	VDD
10	NC
11	LEDK
12	LEDA
13	TE
14	D7
15	D6
16	D5
17	D4
18	D3
19	D2
20	D1
21	D0
22	SDA
23	RD
24	WR/A0

IM1/IM2=0,8080 8bit mode
 IM1/IM2=1,4SPI 1lane mode

- NOTE:
1. DISPLAY TYPE:0.96”TFT, TRANSMISSIVE
 2. DRIVER IC: GC9307
 3. VIEWING DIRECTION: FREE
 4. OPERATING TEMPERATURE:-10°C--+60°C.
 5. STORAGE TEMPERATURE:-20°C--+70°C.
 6. BACKLIGHT TYPE:2 WHITE LEDs.
 7. LED:If=20.0mA/LED (CONSTANT CURRENT).
 8. (...) REFERENCE DIMENSION.
 9. "☒" ICON MEAN CRITICAL DIM
 10. MUST MEET THE REQUIREMENT OF ROHS

APPROVALS	DATE	SCALE	TITLE	
DRAWN: Frank	2019.10.10		MODULE	
CHECK: Howlin	2019.10.10	UNIT mm		
APPROVAL: Owen	2019.10.10	MODEL		
			A1	PAGE 1/1

3. Interface description

Pin No.	Symbol	I/O	Description
1	VSS	P	GND
2	IM1\IM2	I	IM1/IM2=0,8080 8bit mode IM1/IM2=1,4SPI 1lane mode
3	RES	I	Hardware Reset input pin
4	NC	-	Open
5	CS	I	Chip select input pins
6	DCX/SCL	I	SPI mode: Serial clock input 8080 mode: data and command select pin
7	NC	-	open
8	VDDIO	P	Power source for I/O circuit
9	VDD	P	Power source for system circuit
10	NC	-	open
11	LEDK	P	Backlight -
12	LEDA	P	Backlight +
13	TE	O	Tearing effect signal is used to synchronize MCU to frame memory
14	D7	I/O	Parallel interface data bus
15	D6		
16	D5		
17	D4		
18	D3		
19	D2		
20	D1		
21	D0		
22	SDA	I	Serial data input
23	RD	I	Read enable in 8080 mode
24	WR/A0	I	8080 mode: write enable SPI mode: data and command select pin

4. Absolute Maximum Ratings

Item	Symbol	Min	Max	Unit
Analog supply voltage	AVDD	-0.3	4.6	V
Logic supply voltage	IOVDD	-0.3	4.6	V
Operating temperature range	Top	-10	+60	°C
Storage temperature range	Tst	-20	+70	°C
Storage humidity	HD	-	90	%RH

5. DC Characteristics

Item	Symbol	Min	TYP	Max	Unit	Remark
System supply voltage	AVDD	2.4	2.8	3.3	V	-
I/O supply voltage	IOVDD	1.65	1.8	3.3	V	-
Input high voltage	V _{IH}	0.7IOVDD	-	IOVDD	V	-
Input low voltage	V _{IL}	GND	-	0.3IOVDD	V	-
Output high voltage	V _{OH}	0.8IOVDD	-	IOVDD	V	I _{OH} =-1.0mA
Output low voltage	V _{OL}	GND	-	0.2IOVDD	V	I _{OL} =1.0mA
I/O leak current	I _{LI}	-		1	uA	

6. Timing Characteristics

6.1 Power ON/OFF Sequence

VIO28 and VIO18 can be applied in any order.

VIO28 and VIO18 can be power down in any order.

During power off, if LCD is in the Sleep Out mode, VIO28 and VIO18 must be powered down minimum 120msec after RESET has been released.

During power off, if LCD is in the Sleep In mode, VIO28 and VIO18 can be powered down minimum 0msec after RESET has been released.

CS can be applied at any timing or can be permanently grounded. RESET has priority over CS.

Note 1: There will be no damage to the display module if the power sequences are not met.

Note 2: There will be no abnormal visible effects on the display panel during the Power On/Off Sequences.

Note 3: There will be no abnormal visible effects on the display between end of Power On Sequence and before receiving Sleep Out command. Also between receiving Sleep In command and Power Off Sequence.

Note 4: If LSRES line is not held stable by host during Power On Sequence as defined in the sequence below, then it will be necessary to apply a Hardware Reset (RESET) after Host Power On Sequence is complete to ensure correct operation. Otherwise function is not guaranteed.

The power on/off sequence is illustrated below

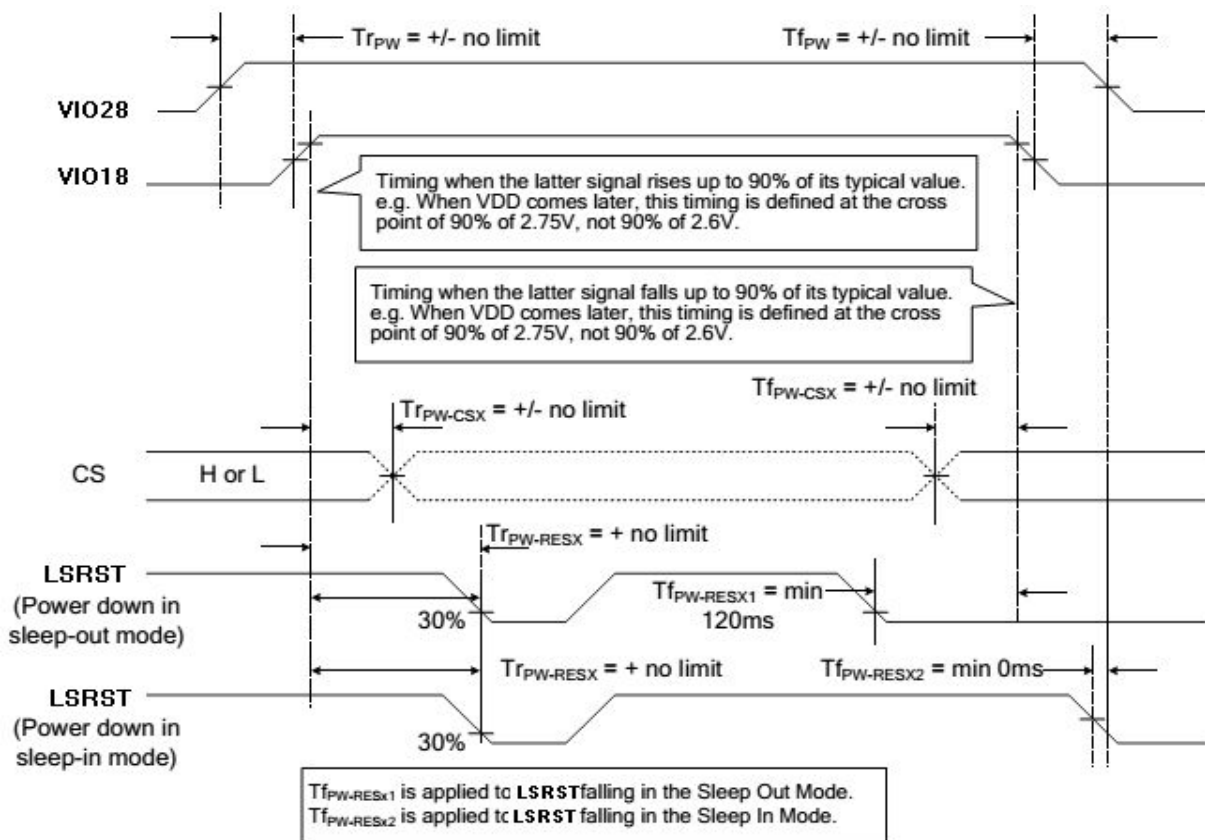

Uncontrolled Power Off

The uncontrolled power-off means a situation which removed a battery without the controlled power off sequence. It will neither damage the module or the host interface.

If uncontrolled power-off happened, the display will go blank and there will not any visible effect on the display (blank display) and remains blank until "Power On Sequence" powers it up.

6.2 Send data sequence

4-line serial mode

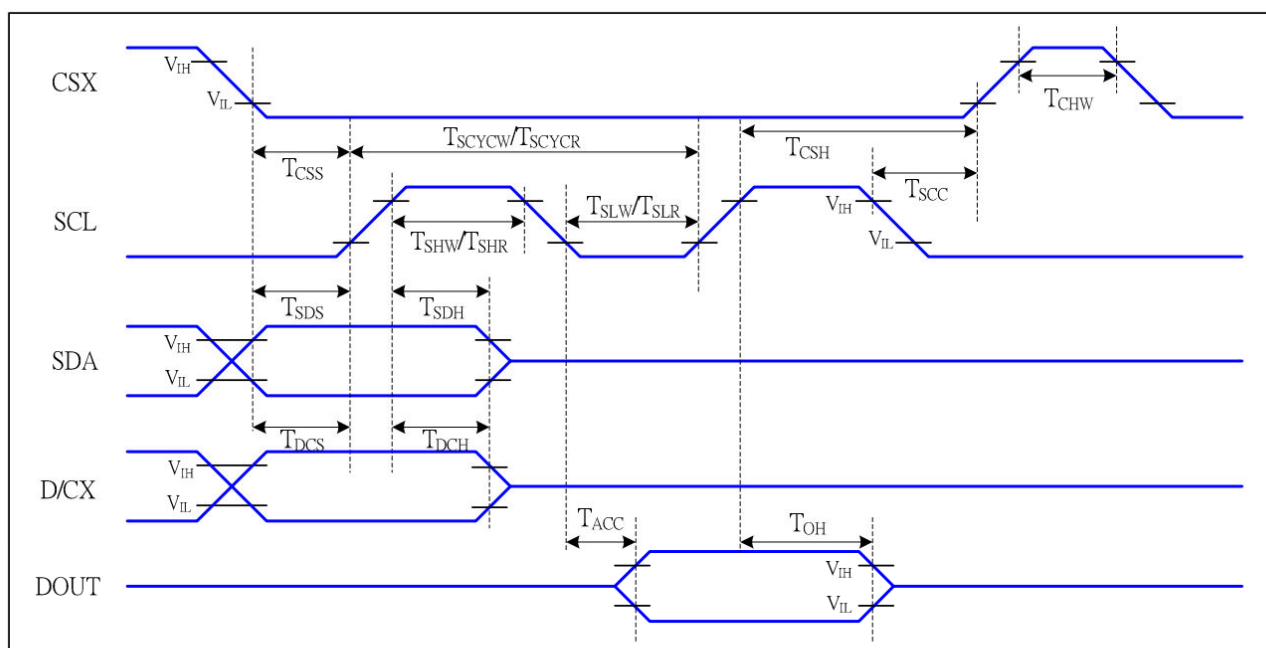

Figure 5 4-line serial Interface Timing Characteristics

V_{DDI}=1.65 to 3.3V, V_{DD}=2.4 to 3.3V, A_{GND}=D_{GND}=0V, T_a=25°C

Signal	Symbol	Parameter	MIN	MAX	Unit	Description
CSX	T _{CSS}	Chip select setup time (write)	15		ns	
	T _{CSH}	Chip select hold time (write)	15		ns	
	T _{CSS}	Chip select setup time (read)	60		ns	
	T _{SCC}	Chip select hold time (read)	65		ns	
	T _{CHW}	Chip select "H" pulse width	40		ns	
SCL	T _{SCYCW}	Serial clock cycle (Write)	16		ns	-write command & data ram
	T _{SHW}	SCL "H" pulse width (Write)	7		ns	
	T _{SLW}	SCL "L" pulse width (Write)	7		ns	
	T _{SCYCR}	Serial clock cycle (Read)	150		ns	-read command & data ram
	T _{SHR}	SCL "H" pulse width (Read)	60		ns	
	T _{SLR}	SCL "L" pulse width (Read)	60		ns	
D/CX	T _{DCS}	D/CX setup time	10		ns	
	T _{DCH}	D/CX hold time	10		ns	
SDA (DIN)	T _{SDS}	Data setup time	7		ns	
	T _{SDH}	Data hold time	7		ns	
DOUT	T _{ACC}	Access time	10	50	ns	For maximum CL=30pF
	T _{OH}	Output disable time	15	50	ns	For minimum CL=8pF

8080 Mode

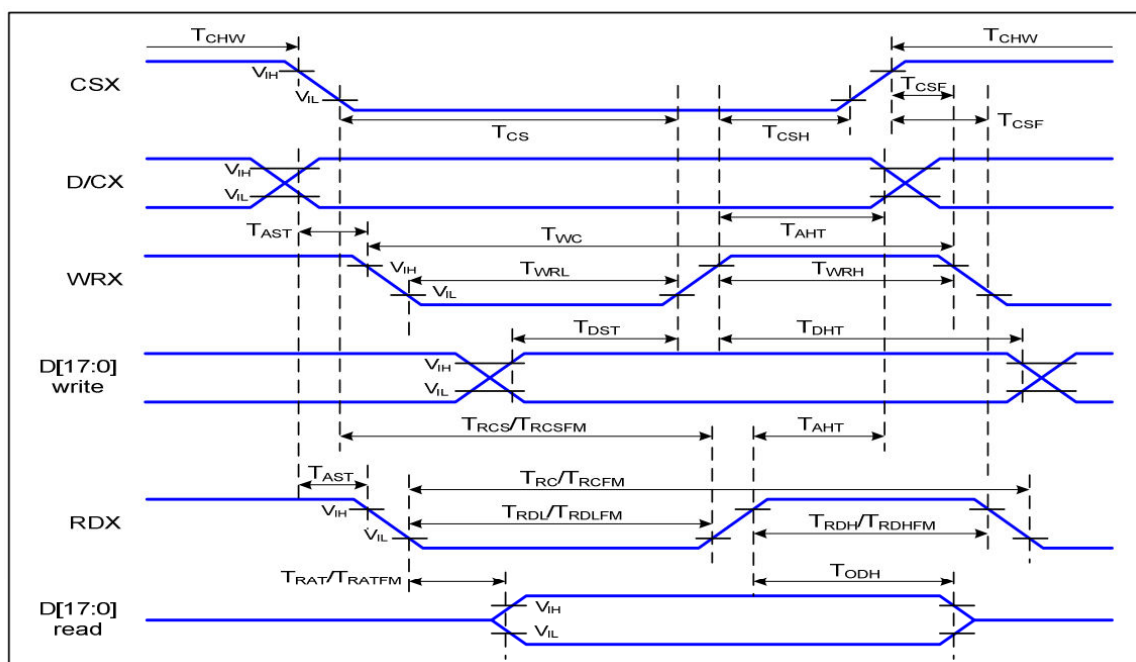
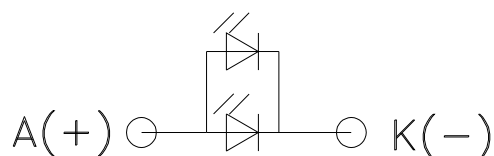

Figure 1 Parallel Interface Timing Characteristics (8080-Series MCU Interface)

VDDI=1.65 to 3.3V, VDD=2.4 to 3.3V, AGND=DGND=0V, Ta=25°C

Signal	Symbol	Parameter	Min	Max	Unit	Description
D/CX	T_{AST}	Address setup time	0		ns	-
	T_{AHT}	Address hold time (Write/Read)	10		ns	
CSX	T_{CHW}	Chip select "H" pulse width	0		ns	-
	T_{CS}	Chip select setup time (Write)	15		ns	
	T_{RCS}	Chip select setup time (Read ID)	45		ns	
	T_{RCSFM}	Chip select setup time (Read FM)	355		ns	
	T_{CSF}	Chip select wait time (Write/Read)	10		ns	
	T_{CSH}	Chip select hold time	10		ns	
WRX	T_{WC}	Write cycle	66		ns	
	T_{WRH}	Control pulse "H" duration	15		ns	
	T_{WRL}	Control pulse "L" duration	15		ns	
RDX (ID)	T_{RC}	Read cycle (ID)	160		ns	When read ID data
	T_{RDH}	Control pulse "H" duration (ID)	90		ns	
	T_{RDL}	Control pulse "L" duration (ID)	45		ns	
RDX (FM)	T_{RCFM}	Read cycle (FM)	450		ns	When read from frame memory
	T_{RDHFM}	Control pulse "H" duration (FM)	90		ns	
	T_{RDLFM}	Control pulse "L" duration (FM)	355		ns	
D[17:0]	T_{DST}	Data setup time	10		ns	For CL=30pF

7. Backlight Characteristics



$$V_f = 2.9 - 3.3V, I_f = 40mA$$

8. Electron-optical Characteristics

8.1 Parameters specifications

Parameter		Symbol	Condition	Min.	Typ.	Max.	Unit
Threshold Voltage		V _{sat}		4.1	4.3	4.5	V
		V _{th}		1.6	1.8	2.0	V
Viewing Angle	Horizontal	θ ₃	CR > 10	75	80		°
		θ ₉		75	80		°
	Vertical	θ ₁₂		75	80		°
		θ ₆		75	80		°
Contrast Ratio		CR	θ = 0°	700	900		
Transmittance		T(%)	θ = 0°	6.0	6.4		
NTSC		%	θ = 0°	45	50		
Reproduction Of color	Red	R _x	θ = 0°	0.610	0.625	0.640	
		R _y		0.296	0.311	0.326	
	Green	G _x		0.281	0.296	0.311	
		G _y		0.502	0.517	0.532	
	Blue	B _x		0.128	0.143	0.158	
		B _y		0.129	0.144	0.159	
White		W _x	θ = 0°	0.283	0.298	0.313	
		W _y		0.313	0.328	0.343	
Response Time		Tr+Tf	θ = 0°		30	35	ms

8.2 Definitions and measuring methods

[1] Response Time(T_r 、 T_f)

The rise time ' T_r ' is defined as the time for luminance to change from 90% to 10% as a result of a change of the electrical condition. The fall time ' T_f ' is defined as the time for luminance to change from 10% to 90% as a result of a change of the electrical condition.

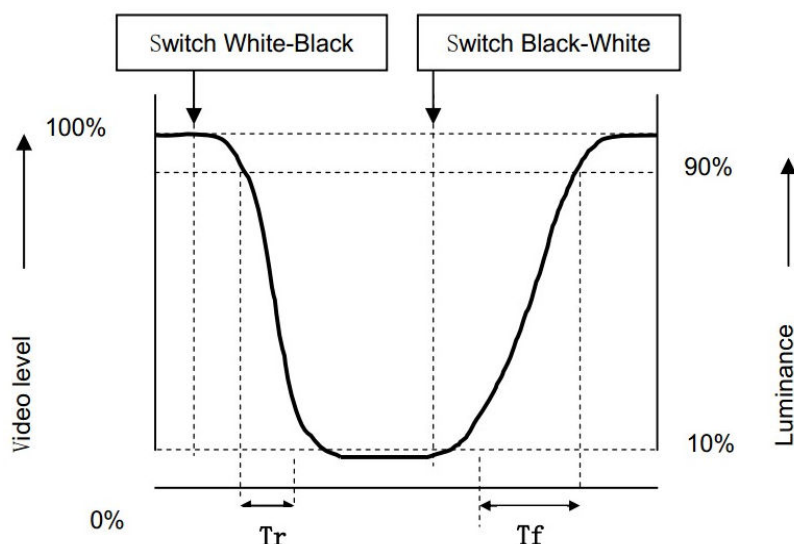

[2] Contrast ratio (Cr)

The contrast ratio (Cr), measured on a module, is the ratio between the luminance (L_w) in a full white area ($R=G=B=1$) and the luminance (L_d) in a dark area ($R=G=B=0$):

$$Cr = \frac{L_w}{L_d}$$

[3] Viewing angle diagram

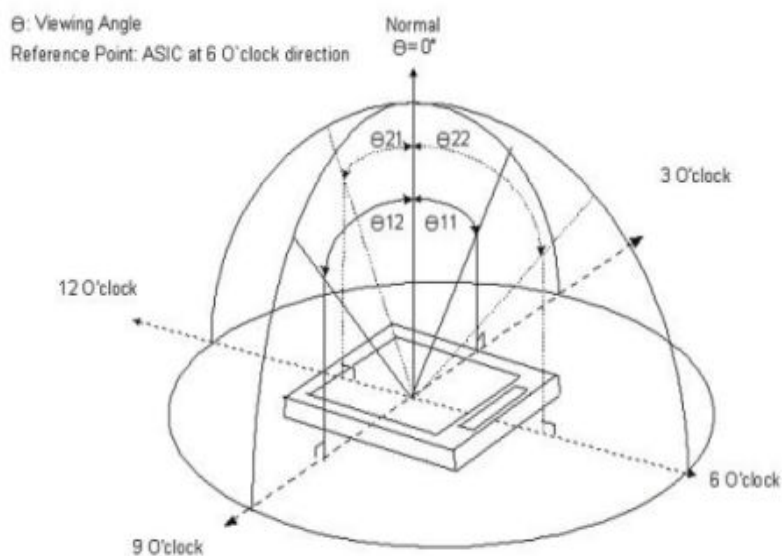

[4] Definition of color gamut

Measuring machine:CFT-01. NTSC'S Primaries: R(x,y,Y)、 G(x,y,Y)、 B(x,y,Y).

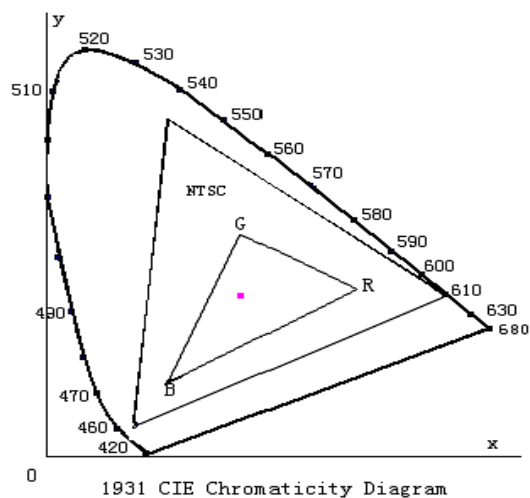

Fig. 1931 CIE chromaticity diagram

$$\text{Color gamut: } \mathcal{G} = \frac{\text{Area of RGB triangle}}{\text{Area of NTSC triangle}} \times 100\%$$

[5] Definition of luminance uniformity

Active area is divided into 5 measuring areas, every measuring points is placed at the center of each measuring area.

luminance uniformity=Lmin/Lmax.

L:Active area length .

W:Active area width.

Lmax:The measured maximum luminance of all measurement position.

Lmin :The measured minimum luminance of all measurement position.

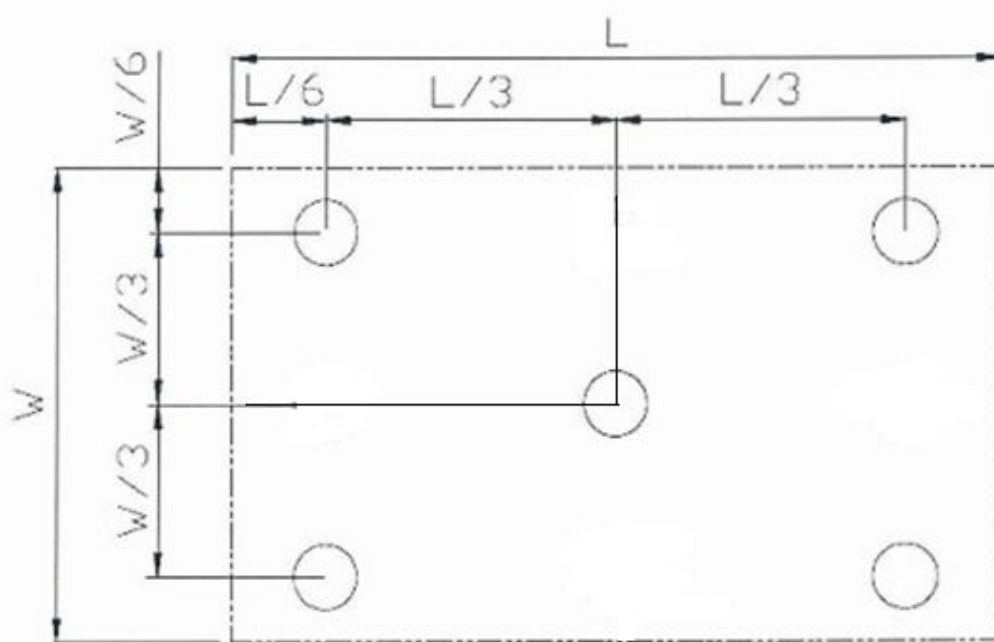

[6] Definition of luminance

Measure the luminance of white state at center point.

9. Reliability test conditions and methods

No	Test Item	Test condition	Criterion
1	High Temperature Storage	70°C±3°C 48H Power off	Inspection after 4 hours storage at room temperature, the sample shall be free from defects: <ol style="list-style-type: none"> 1. Air bubble in the LCD; 2. Seal leak; 3. Non-display; 4. missing segments; 5. Glass crack; 6. Current I_{dd} is twice higher than initial value. 7. The surface shall be free from damage. 8. The electric characteristic requirements shall be satisfied
2	Low Temperature Storage	-10°C±3°C 48H Power off	
3	High Temperature Operation	60°C±3°C 48H Power on	
4	Low Temperature Operation	-20°C±3°C 48H Power on	
5	High Temperature & Humidity Operation	40°C±3°C 90%RH 48H Power off	
6	Temperature Cycle	-20°C←→25°C←→70°C 30min 5min 30min 5 cycle Power off	

Remark:

1. The test samples should be applied to only one test item.
2. Sample size for each test item is 3~5pcs.
3. For Damp Proof Test, Pure water (Resistance > 10MΩ) should be used.
4. In case of malfunction defect caused by ESD damage, if it would be recovered to normal state after resetting, it would be judged as a good part.
5. EL evaluation should be excepted from reliability test with humidity and temperature: Some defects such as black spot/blemish can happen by natural chemical reaction with humidity and Fluorescence EL has.
6. Failure Judgment Criterion: Basic Specification, Electrical Characteristic, Mechanical Characteristic, Optical Characteristic.

10. Quality standards

10.1 Dot defects(operation)

Item	Size(mm)	Acceptable number	Remark
Bright dots (red / green / blue)	$D \leq 0.1$	Neglected	MI
	$0.1 < D \leq 0.25$	max, 2	MI
	$0.25 < D$	0	MI
Black dots	-	max, 2	Not adjoining black dots
	-	0	adjacent black dots

10.2 Major defects

Item	Acceptable number	Remark
Function defect	not allowed	
Abnormal operation including distinct RGB line defects and white line defect	not allowed	
RGB timing	not allowed	
Wrong color	not allowed	
Less brightness	not allowed	
No backlight	not allowed	
Broken glass	not allowed	

10.3 Minor defects (visual)

Item	Size(mm)	Acceptable number	Remark
Black spots or white spots	$D < 0.15$	Neglected	(Note1)
	$0.15 < D \leq 0.25$	max, 2	
	$0.25 < D$,	max, 0	
Black lines,white lines	$W \leq 0.03$	Neglected	(Note2)
	$0.03 < W \leq 0.05$ $L \leq 2$,	max, 2	
	$0.05 < W$	max, 0	

Note1

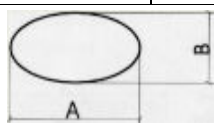

$$D = (A+B) / 2$$

Note2

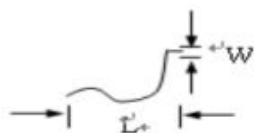

L: 长度

W: 宽度

11. Handling precautions

11.1 Mounting method

The LCD panel of SC LCD module consists of two thin glass plates with polarizers which easily be damaged. And since the module is so constructed as to be fixed by utilizing fitting holes in the printed circuit board.

Extreme care should be needed when handling the LCD modules.

11.2 Caution of LCD handling and cleaning

When cleaning the display surface, Use soft cloth with solvent [recommended below] and wipe lightly

Isopropyl alcohol

Ethyl alcohol

Do not wipe the display surface with dry or hard materials that will damage the polarizer surface.

Do not use the following solvent:

Water

Aromatics

Do not wipe ITO pad area with the dry or hard materials that will damage the ITO patterns

Do not use the following solvent on the pad or prevent it from being contaminated:

Soldering flux

Chlorine (Cl) , Sulfur (S)

If goods were sent without being silicic acid coated on the pad, ITO patterns could be damaged due to the corrosion as time goes on.

If ITO corrosion happens by miss-handling or using some materials such as Chlorine (Cl), Sulfur (S) from customer, Responsibility is on customer.

11.3 Caution against static charge

The LCD module uses C-MOS LSI drivers, so we recommend that you:

Connect any unused input terminal to V_{dd} or V_{ss}, do not input any signals before power is turned on, and ground your body, work/assembly areas, assembly equipment to protect against static electricity.

11.4 Packing

Module employs LCD elements and must be treated as such.

Avoid intense shock and falls from a height.

To prevent modules from degradation, do not operate or store them exposed directly to sunshine or high temperature/humidity

11.5 Caution for operation

It is an indispensable condition to drive LCD's within the specified voltage limit since the higher voltage than the limit causes the shorter LCD life.

An electrochemical reaction due to direct current causes LCD's undesirable deterioration, so that the use of direct current drive should be avoided.

Response time will be extremely delayed at lower temperature than the operating temperature range and on the other hand at higher temperature LCD's show dark color in them. However those phenomena do not mean malfunction or out of order with LCD's, which will come back in the specified operation temperature.

If the display area is pushed hard during operation, some font will be abnormally displayed but it resumes normal condition after turning off once.

A slight dew depositing on terminals is a cause for electro-chemical reaction resulting in terminal open circuit.

Usage under the maximum operating temperature, 50%RH or less is required.

11.6 Storage

In the case of storing for a long period of time for instance, for years for the purpose of replacement use, the following ways are recommended.

Storage in a polyethylene bag with the opening sealed so as not to enter fresh air outside in it. And with no desiccant.

Placing in a dark place where neither exposure to direct sunlight nor light's keeping the storage temperature range.

Storing with no touch on polarizer surface by the anything else.

[It is recommended to store them as they have been contained in the inner container at the time of delivery from us

11.7 Safety

It is recommendable to crash damaged or unnecessary LCD's into pieces and wash off liquid crystal by either of solvents such as acetone and ethanol, which should be burned up later.

When any liquid leaked out of a damaged glass cell comes in contact with your hands, please wash it off well with soap and water

12. Precaution For Use

A limit sample should be provided by the both parties on an occasion when the both parties agreed its necessity. Judgment by a limit sample shall take effect after the limit sample has been established and confirmed by the both parties.

On the following occasions, the handing of problem should be decided through discussion and agreement between responsible of the both parties.

When a question is arisen in this specification

When a new problem is arisen which is not specified in this specifications

When an inspection specifications change or operating condition change in customer is reported to GT LCD , and some problem is arisen in this specification due to the change

When a new problem is arisen at the customer's operating set for sample evaluation in the customer site.